

## Optical Prisms

**Hangzhou Shalom EO offers** a variety of optical prisms: right angle prisms, equal-lateral prisms, porro prisms, rhombic prisms, penta prisms, dove prisms, corner cube retro-reflectors and wedge prisms. The dimension of the prisms ranger from 1mm to 100mm. We are able to process the large volume productions, and are also glad to deal with small quantity of prototypes . A wide range of the optical crystals and optical glass materials are available for substrates.

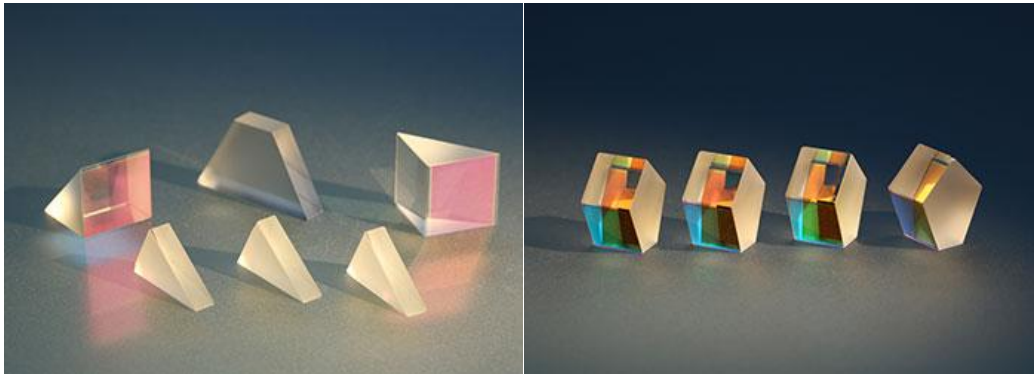

## SPECIFICATIONS

Specifications	
Materials	BK7, B270, FS, BaF2, CaF2, MgF2, Quartz, YAG , Ge, Si, Sapphire, ZnSe, ZnS and other customized materials;
Spherical configurations	Right angle prisms, equal lateral prisms, porro prisms, rhombic prisms, penta prisms, Dove prisms, Corner cube retro-reflectors and wedge prisms.
Size Tolerance	+/-0.1mm
Surface quality(S/D)	40/20 or upon customer's request to 10/5
Aperture	90% of central dimension
Flatness	Lambda/4 @ 633nm or upon customer's request

**Note:** The custom specifications are available upon customer's request.

**Right angle prisms**

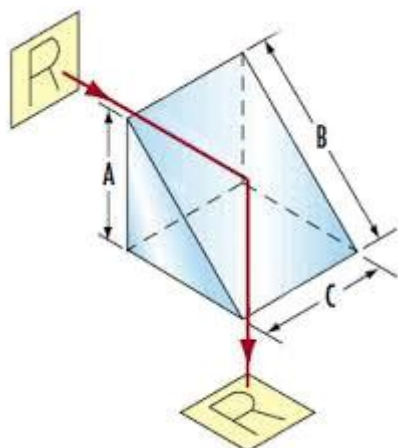

**Euqal-lateral Prisms**

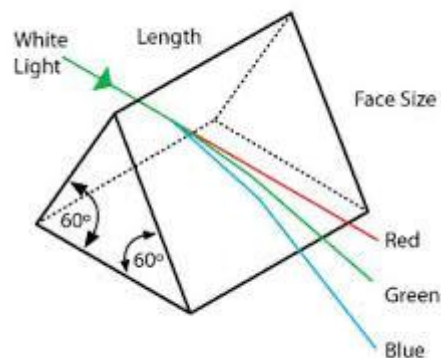

**Penta Prisms**

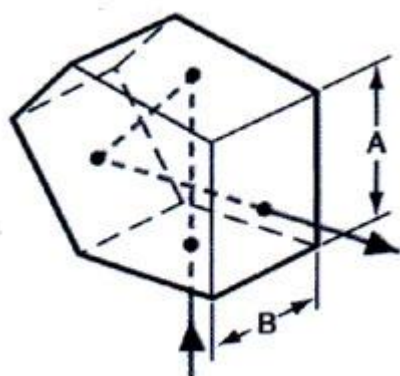

**Porro Prisms**

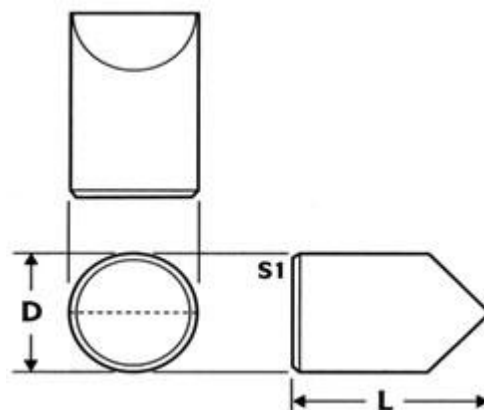

**Corner Cube Retro-reflectors**

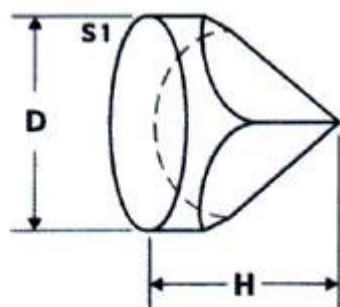

**Rhombic Prisms**

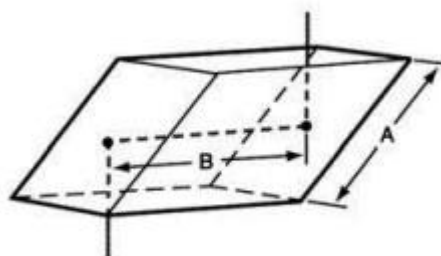

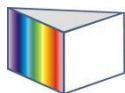

**Dove Prisms**

